



Bottom Paving Corrosion in
Hybrid & High e-Boosting
Furnaces



ICG

International Commission on Glass

TC 11 – Refractory Materials

SEFPRO Refractory Solutions

SGR Provence - December 20th 2023

Confidential, Property of SEFPRO – Do not disclose



Electrical Boosting on Glass Furnaces

Modification of Convection Pattern and Glass Temperature

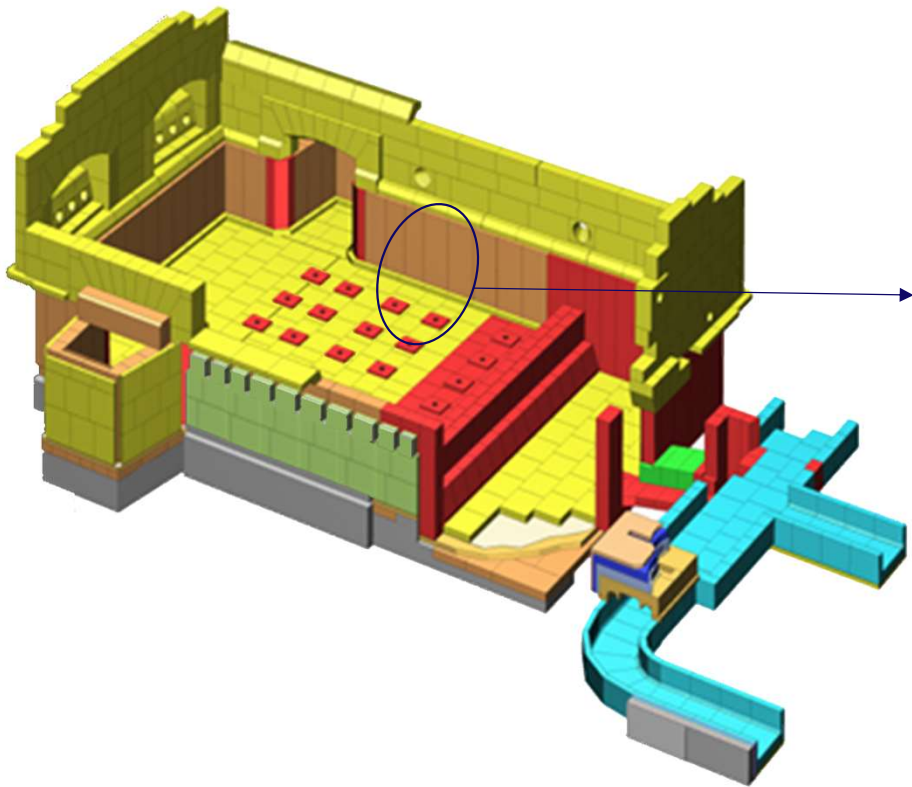

Bottom Paving

At the same time , glass velocity profile increase and glass temperature profile (from CFD simulation results) will enhance all type of corrosion process at the bottom place level such as :

- Direct corrosion
- Upward drilling corrosion process if glass infiltration
- Downward drilling process if metallic contamination

Electrical Boosting on Glass Furnaces

Corrosion Behavior Evolution with Temperature

ER 1711 in Sodalime Glass

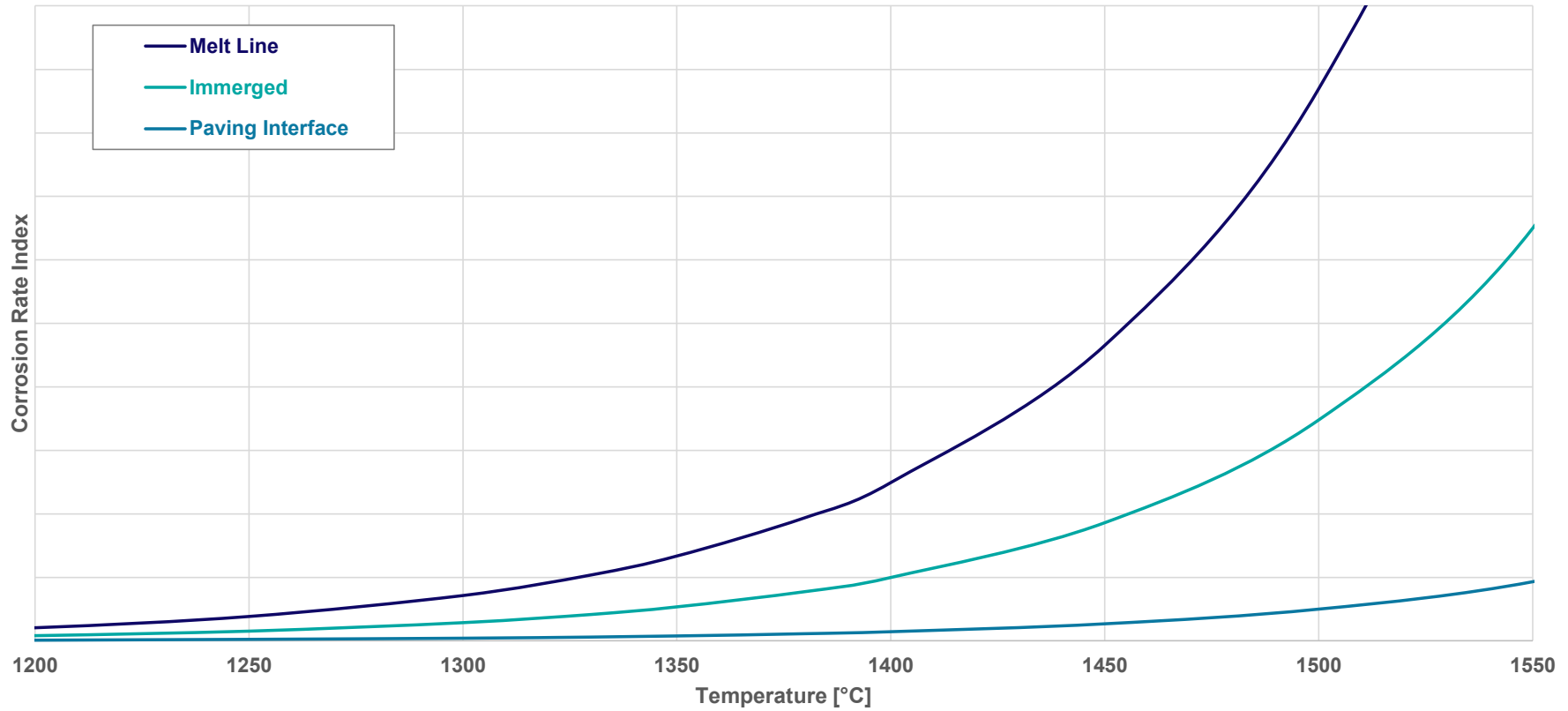

Bottom Paving Corrosion Mechanisms

3 Main Types of Corrosion

DIRECT CORROSION

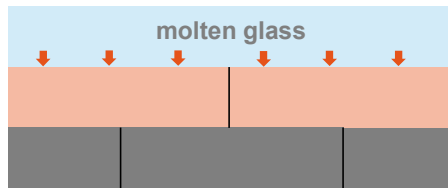

To be addressed but
**RARELY THE CAUSE OF UNEXPECTED
SHUTDOWN**

UPWARD DRILLING

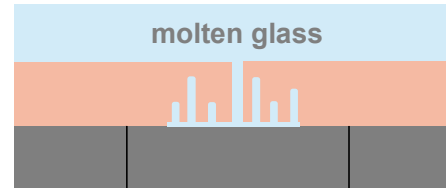

**MAIN SOURCE OF PREMATURE
MAINTENANCE/SHUTDOWN**

DOWNWARD DRILLING

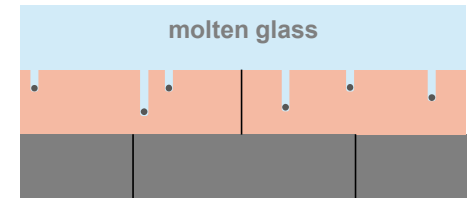

Metallic impurities from cullet



Bottom Paving Corrosion Mechanisms

3 Main Types of Corrosion

DIRECT CORROSION

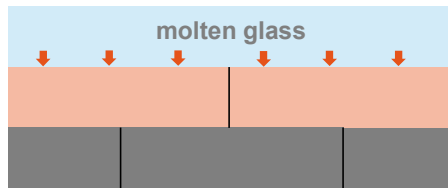

To be addressed but
**RARELY THE CAUSE OF UNEXPECTED
SHUTDOWN**

UPWARD DRILLING



**MAIN SOURCE OF PREMATURE
MAINTENANCE/SHUTDOWN**

DOWNWARD DRILLING



Metallic impurities from cullet



Direct Corrosion of Fused-Cast Refractories

A Well Known and Predictable Behavior

Dynamic Corrosion Tests



Industrial Feedback

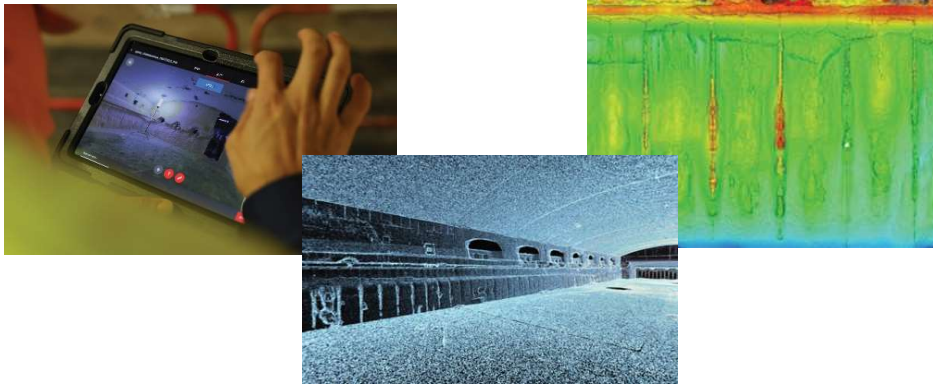

AZS Corrosion Rate in Sodlime Glass

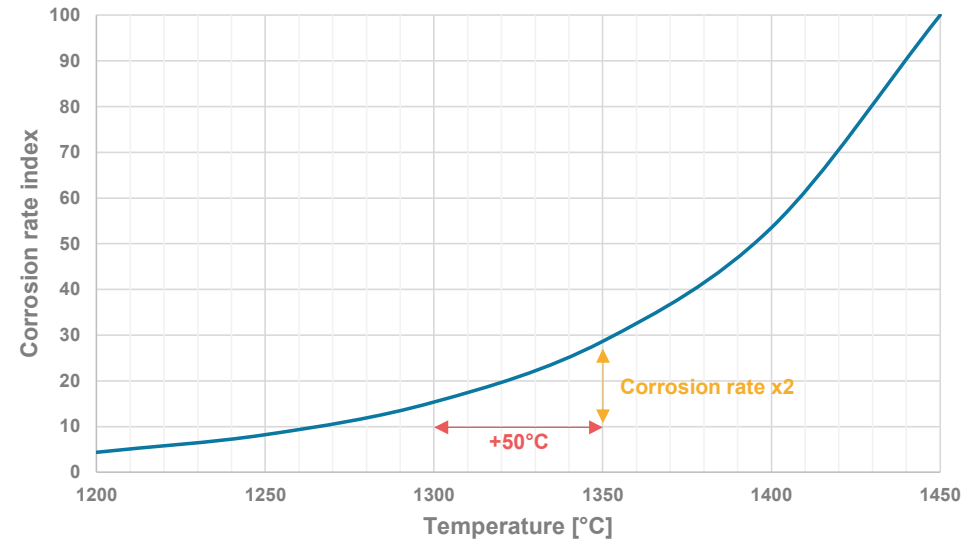

Typical corrosion rates for bottom paving
5 - 15 mm/year

Bottom Paving Corrosion Mechanisms

3 Main Types of Corrosion

DIRECT CORROSION



To be addressed but
RARELY THE CAUSE OF UNEXPECTED
SHUTDOWN

UPWARD DRILLING

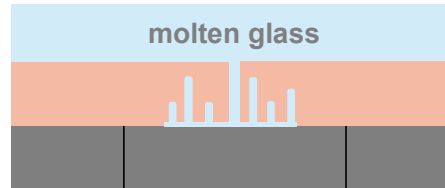

MAIN SOURCE OF PREMATURE
MAINTENANCE/SHUTDOWN

DOWNWARD DRILLING



Metallic impurities from cullet



Upward Drilling Corrosion

Upward drilling is caused by gas bubbles trapped **under a horizontal refractory surface**. The **triple point** (solid / liquid / gas) **disrupts** the formation of the high-viscosity **protective layer** leading to **accelerated corrosion**.

Upward Drilling

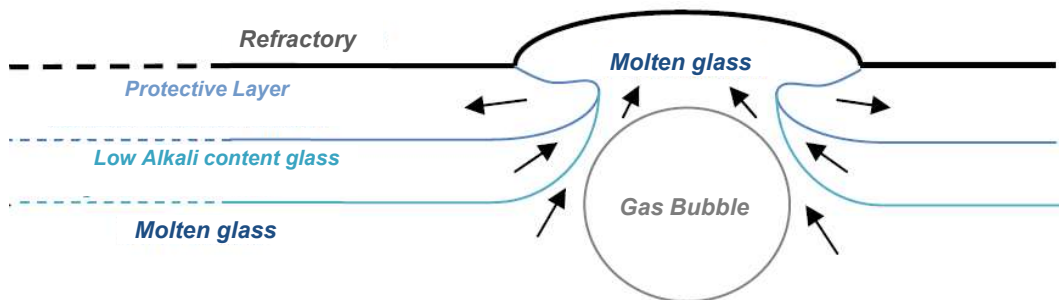

Interface Layer

- High viscosity due to Al content
- Surface tension \gg glass
- Similar/higher density $f(\text{Zr})$

Triple point

- Marangoni effect (surface tension effect)
- Prevents formation of the protective layer
- 'Fresh' glass constantly in contact with refractory material



Typical corrosion rate **hard to quantify**
Assumed to **exceed 50 mm/year** locally

Upward Drilling Corrosion

Lab Characterization

U-shape Test

- Refractory sample in glass cullet (300h)
- Creating a horizontal interface
- Temperature controlled environment

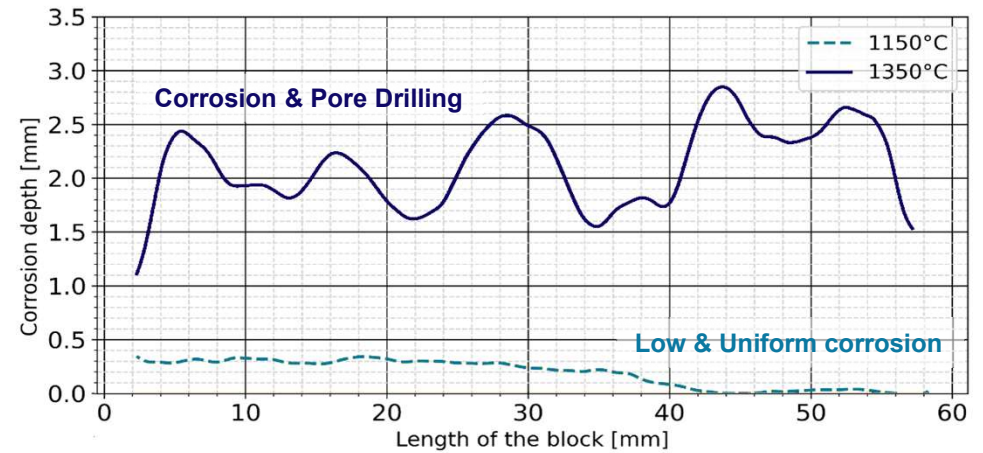
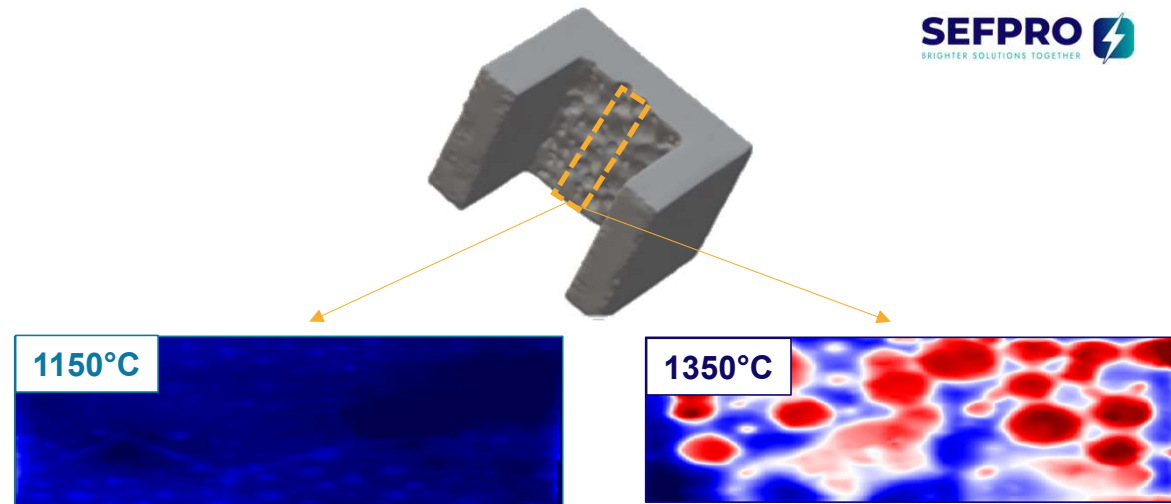
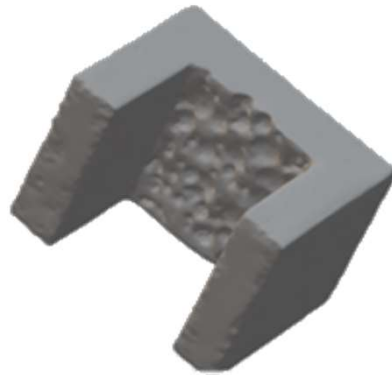
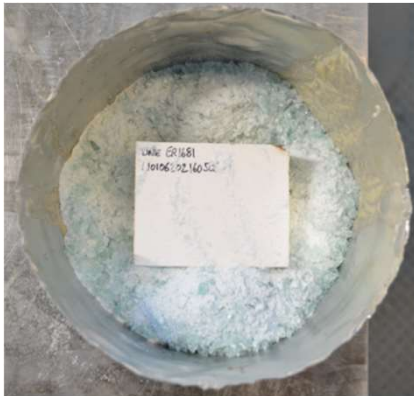

Upward Drilling is a **temperature activated / driven phenomenon.**

Its action seems **limited below 1150°C**

Bottom Paving Corrosion Mechanisms

3 Main Types of Corrosion

DIRECT CORROSION



To be addressed but
RARELY THE CAUSE OF UNEXPECTED
SHUTDOWN

UPWARD DRILLING



MAIN SOURCE OF PREMATURE
MAINTENANCE/SHUTDOWN

DOWNWARD DRILLING

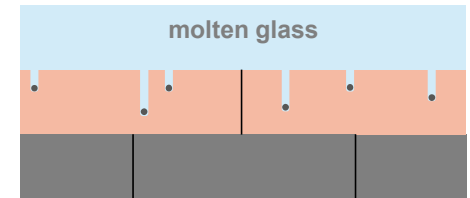

Metallic impurities from cullet



Downward Drilling Corrosion

Downward drilling is caused by **metallic phases** inside the glass bath.
The melted metallic nodules form a **triple point** (solid / liquid / liquid) leading to **accelerated corrosion**.

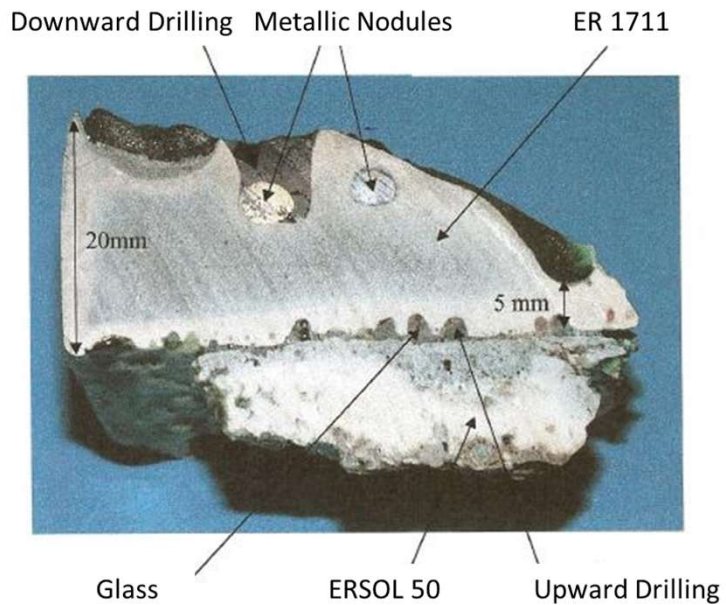

Hard to predict & linked to cullet quality

Bottom Paving Reinforcement

Standard Paving Solution

Key Points

- Internal filling of the tiles (radar control)
- Quality of the joints (TJ machining)
- Fused cast AZS corrosion resistance
- Safety underlayer

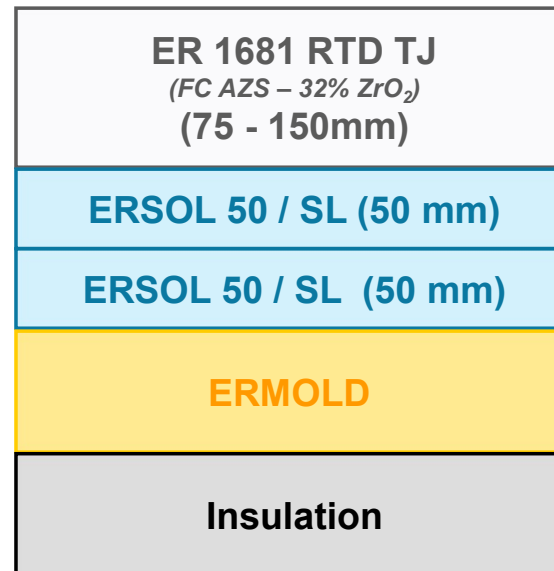
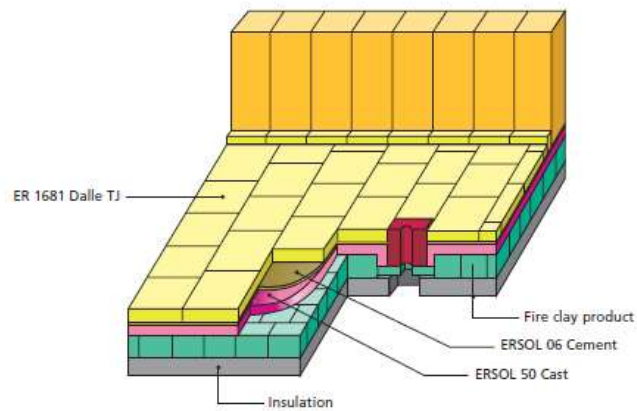

Bottom Paving Reinforcement

Evolution of Paving Solicitations and paving solutions

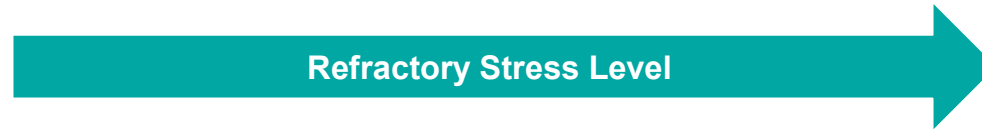

Low boosting & Insulation
1200°C – 1250°C

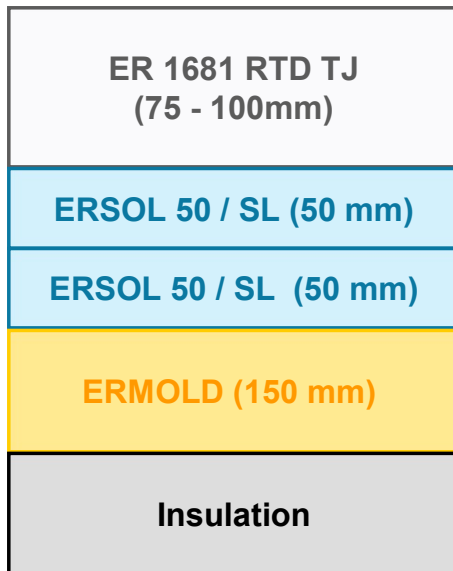

Medium boosting & Low Insulation
1300°C

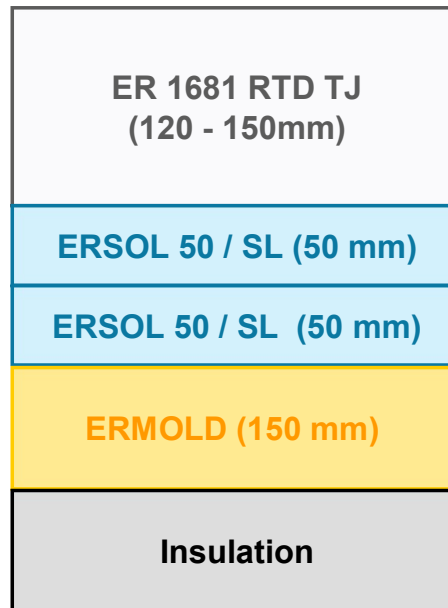

High Boosting & Insulation
1300-1350°C

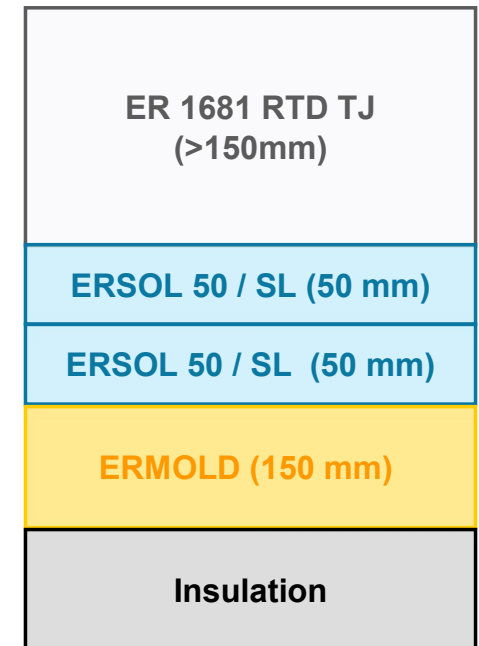

Bottom Paving Reinforcement

Evaluation of Temperature Profile

1D Calculation

- ER 1681 (FC AZS - 32% ZrO₂), 195 mm

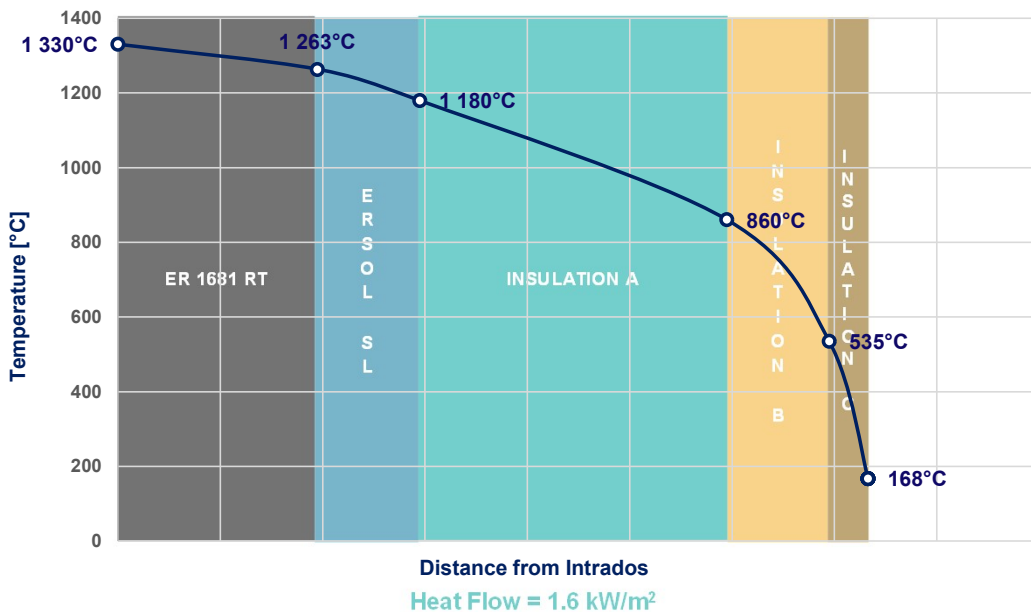

Benefits of Thicker Paving

- Increased lifetime vs direct corrosion & downward drilling
- Reduced temperature below paving
 - Mitigation of upward drilling risk
 - Controlled temperature in ERSOL → optimize joints closing

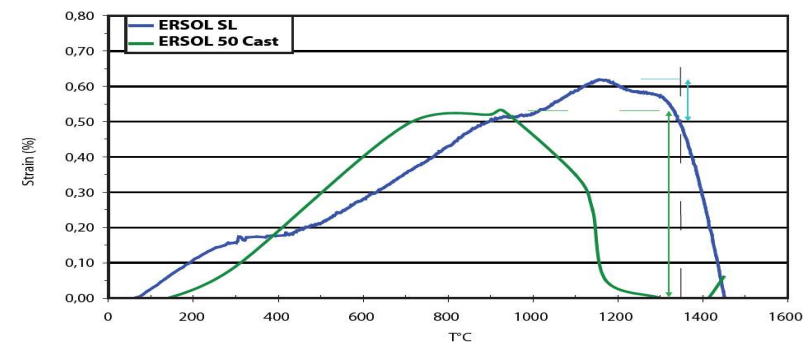
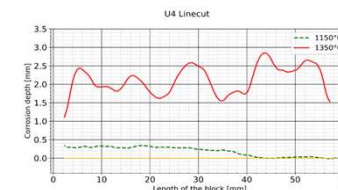

For hybrid or high boosting glass furnace

Thickness recommended > 150 mm

Benefits of Double-Paving Solutions (for high-resistance paving)

Key Points

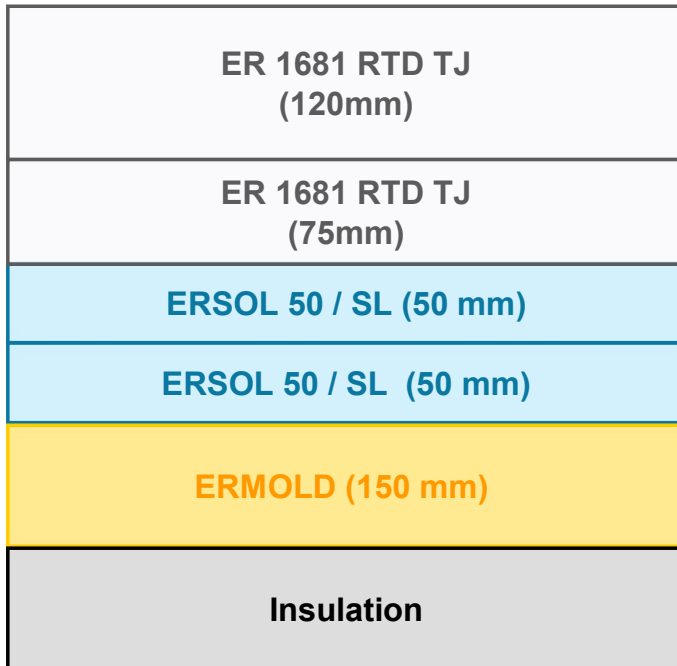

- Limit glass infiltration below AZS tiles

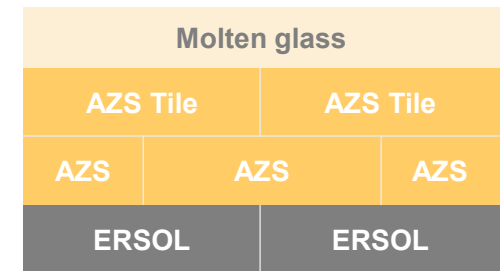
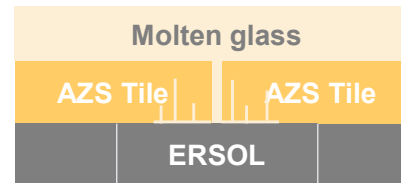

- Keep benefits of tight-joints machining
- Possibility to functionalize top layer
 - ER 2010 RIC
 - FC High-Zirconia

Double-Layer Paving

Typical Designs for Harsh-Conditions Paving

Fused-cast AZS

ER 1681 120mm

ER 1681 75mm

Good corrosion resistance

- Void Free tiles
- Safe refractory thickness

Upward Drilling prevention

- Tight-joints machining
- Crossed joints
- Controlled T° below paving

Premium AZS

ER 2010 RIC 120mm

ER 1681 75mm

Improved corrosion resistance

- Void-free tiles
- Safe refractory thickness

Upward Drilling prevention

- Hot face joint closing + Tight-joints machining
- Crossed joints
- Reduced T° below paving
 - *Reduced thermal conductivity*

FC High-Zirconia

ER 1195 100mm

ER 1681 75mm

Outstanding corrosion resistance

- Void-free tiles
- Safest refractory thickness

Upward Drilling prevention

- Tight-joints machining
- Crossed joints
- Lowest temperature below paving with low thermal conductivity of front layer

Double-Layer Paving

ER 2010 RIC for Secured Bottom Paving

Optimized Joints Closing

- Modified expansion behavior
 - Ensure joints closing at high temperature

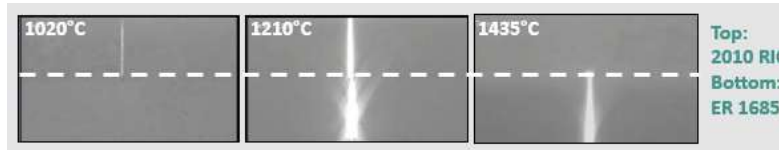
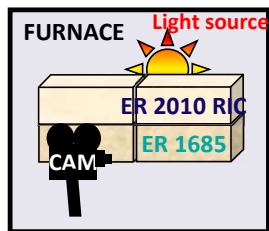
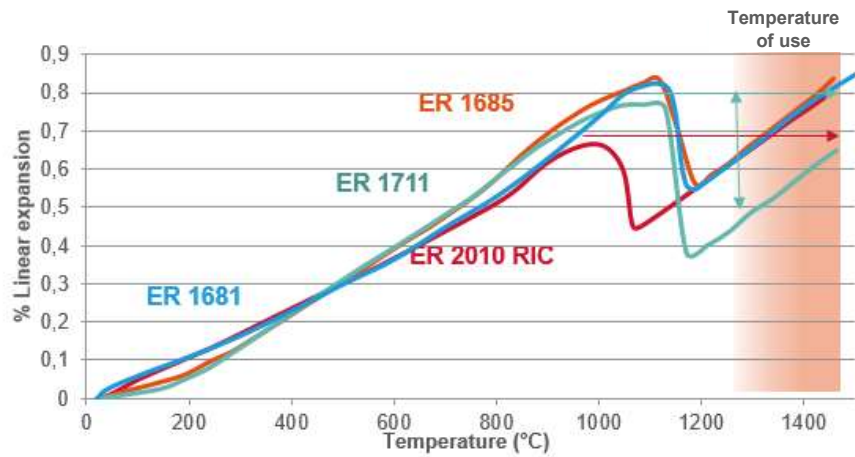

Corrosion Resistance

- Comparable to ER 1711 RT (FC AZS - 40% ZrO₂)

Sodalime Glass 1500°C / 48h	ER 1685 (36% ZrO ₂)	ER 1711 (40% ZrO ₂)	ER 2010 RIC
Corrosion Resistance Index	87	100	100



Double-Layer Paving

ER 2010 RIC for Optimized Joints Closing



Before (top) and after (bottom) :
40 days at 1450 °C with extra-clear sodalime in hot top electric furnace



ER1681



ER2010 RIC

Theory predicts the different joint profiles
from T° gradient and expansion...



Top view of
**theoretical
joint opening...**



...Test Result
demonstrates
a significant
impact on **joint
corrosion** in
favor of **2010
RIC**



Double-Layer Paving

Simulation of Bottom Paving and Electrode Block

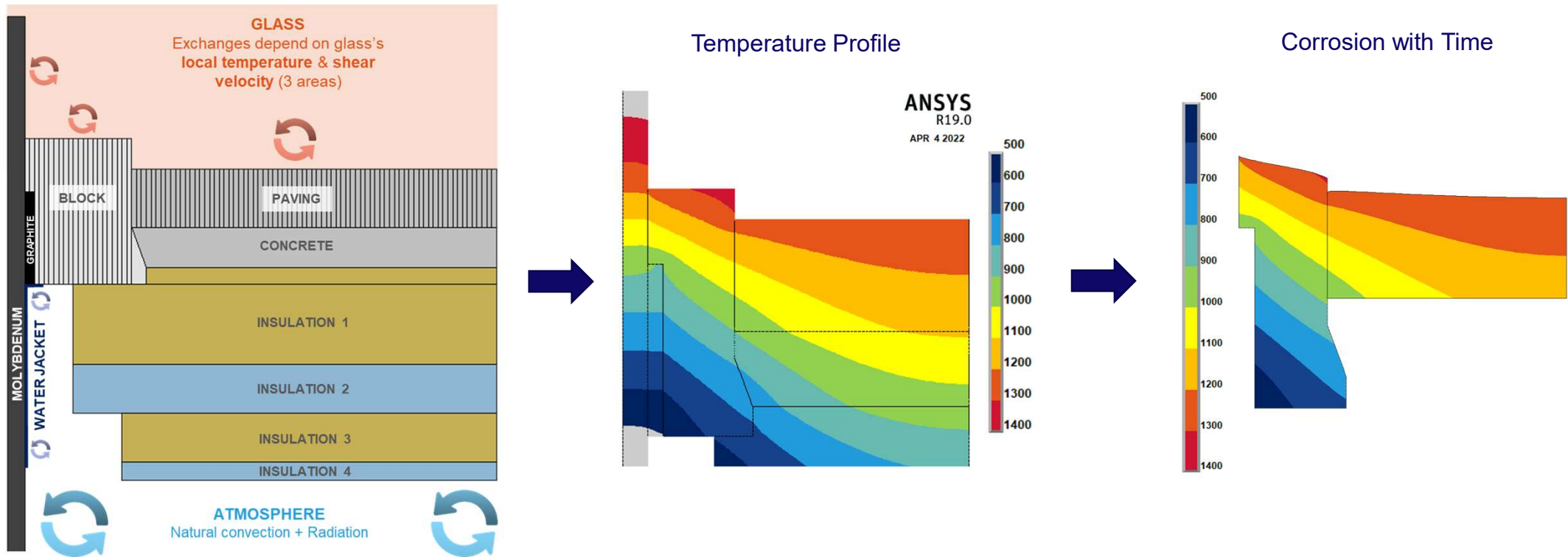

Assessment of the **performances** of bottom paving and electrode block in **specific operating conditions**.

Double-Layer Paving

Simulation of Bottom Paving and Electrode Block

Paving Residual Thickness
End of Campaign

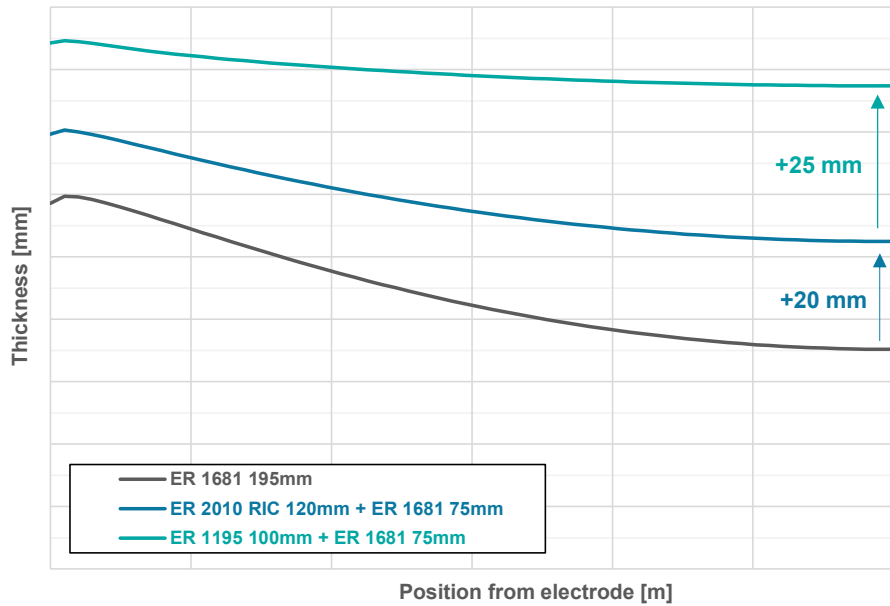

Thermal Losses through Paving

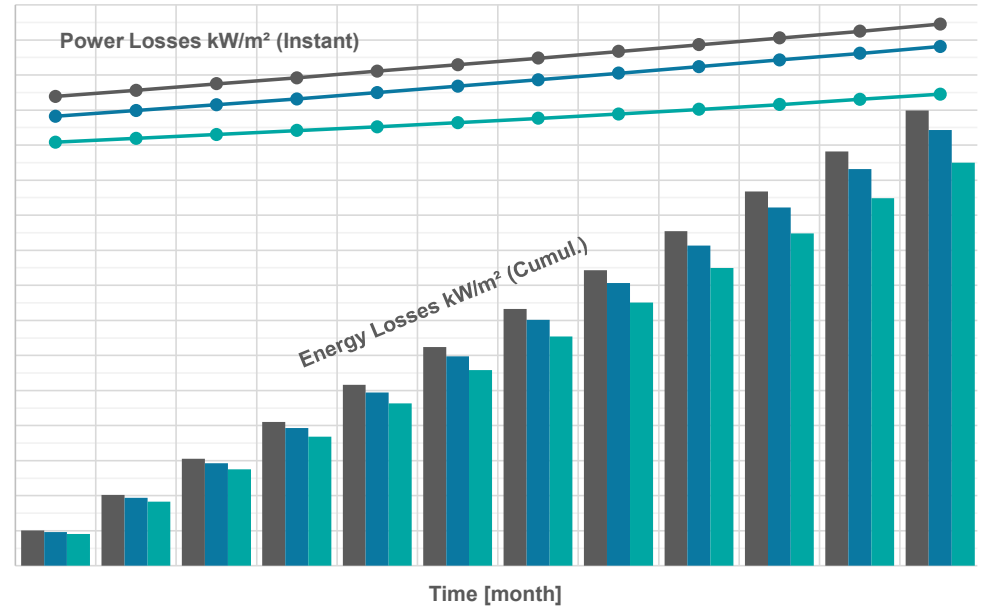

Double-Layer Paving

Simulation of Bottom Paving and Electrode Block

Element	Simulation input parameters	Outcome
Glass	<ul style="list-style-type: none"> - Temperature profile - Velocity profile 	Corrosion Rate Interface temperature Thermal Losses Residual Thickness
Refractory Tiles	<ul style="list-style-type: none"> - Refractory material - Thickness - Layers design 	
Insulation & Concrete	<ul style="list-style-type: none"> - Layers design - Thickness 	
Electrode Block	<ul style="list-style-type: none"> - Geometry - Refractory material - Water cooling system 	

Provide **tailored information to support the refractory materials selection** of each industrial project

Conclusions

Refractory Solutions to Secure Bottom Paving in Highly Boosted Furnace

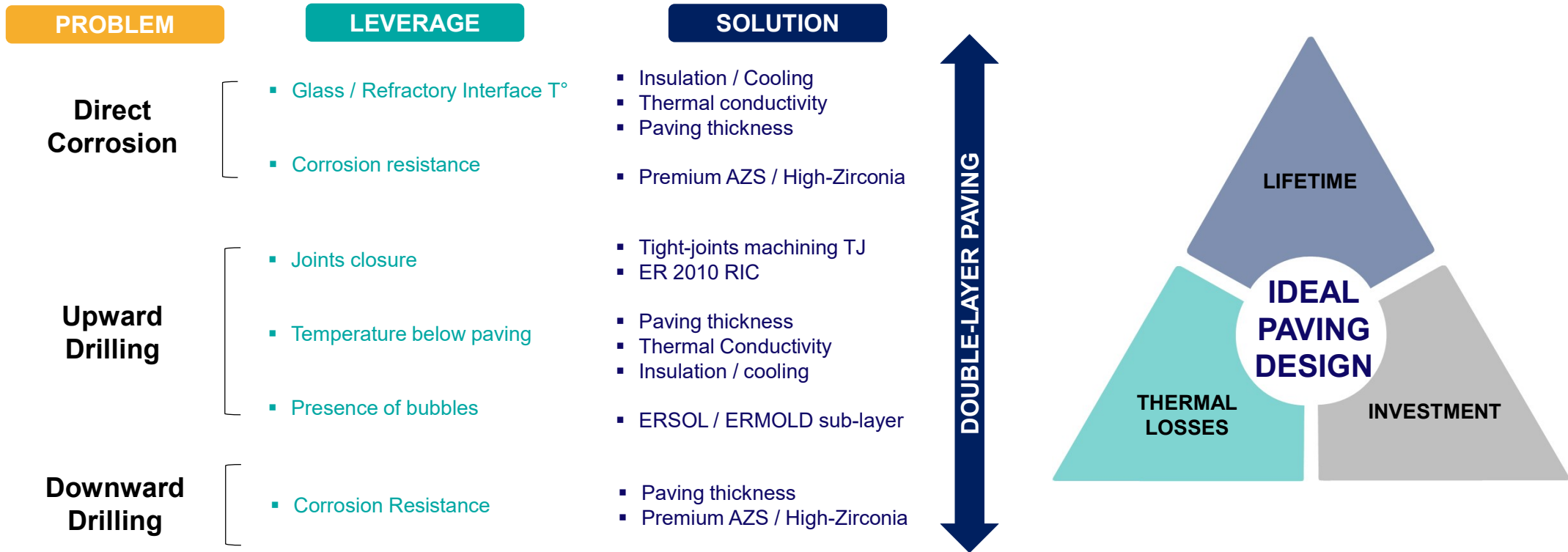

SEFPRO Numerical Simulation Services Offer





Contacts

Michel GAUBIL

Refractory Solutions Director

Michel.Gaubil@saint-gobain.com

Stephane SCHALLER

Energy Solutions Project Leader

Stephane.Schaller@saint-gobain.com

| Thank you